



5.56 X 45 MM (.223 REM)

BALL FMJ M193 - 3,56 g (55 gr)

5.56 x 45 mm FMJ

The cartridge consists of case, primer, gunpowder and bullet. It is applicable in extreme polar or desert conditions, contributing to the versatility of its use.

5.56 x 45 mm – FMJ bullet

The FMJ (Full Metal Jacket) bullet weighs 3.56 g (55 gr) and features a lead core for reliable penetration and performance. The jacket is made of CuZn10, providing durability and ensuring consistent performance.

5.56 x 45 mm – case

The caliber 5.56 x 45 mm CuZn30 case is intended for inserting the powder charge, primer and bullet.

SPECIFICATIONS

Technical Specification

CARTRIDGE

Caliber	.223 REM
Weight	max 12.10 g
Length	max 57.40mm

BULLET GRAIN

Type	FMJ, Ball
Weight	3.56 g ± 0.06 g (55 grain)
Length	max 19.5 mm
Material	Jacket - CuZn10; Core - Lead
Extraction	≤ 156 N

CASE

Length	max 44.7 mm
Material	CuZn30

PRIMER

Type	Boxer, non-corrosive, non-toxic
Propellant	Smokeless Powder (Double Base)
Waterproof	Sealant applied

The 223 Rem., Ball, ammunition producing in ATS AMMO is in compliance with MIL-C-9963F production and test instruction in which are included MIL-STD-105; MIL-STD-109; MIL-STD-636; SCATAP - 5.56 and C.I.P.

ELECTRONIC PRESSURE AND VELOCITY (KIAG 6215)			
Ammunition Temperature	+21°C ± 2°C	+52°C & -54°C	
Velocity (at 24 m, m/s)	$V = 965 \pm 12$ m/s	Max Velocity Difference between +52°C/ -54°C and 21°C samples is not decreased more by 78m/s	
Standard Deviation	≤ 12 m/s	No requirement	
Max Corrected Mean Case Mouth Pressure, MPa	$XCP + 3SD \leq 420$ Mpa	Max case mouth difference between +52°C/ -54°C and 21°C samples is not increased by 38 Mpa	
Max Corrected Mean Port Pressure, MPa	$XPP = 99 \pm 14$ Mpa	Max port pressure difference between +52°C/ -54°C and 21°C samples is ± 14 Mpa	
Action Time (ms)	≤ 3 ms	No requirement	
Muzzle Energy (at 24 m, J)	≤ 1500 J	No requirement	
Precision (at 183 m)	$Mr \leq 50.08$ mm		
Function and Casualty	Permissible percentage of defects was not exceeded		
Primer sensitivity critical high method (run down)	Test ball 111.7 ± 0.57 g	H +5 SD ≤ 450	H - 2 SD ≤ 75
Waterproof test	No more than 15% of the tested rounds have leaks		

Compatibility with: MIL-C-9963F, C.I.P.

PACKING	
Micro	20 rounds fiberboard box
Makro	540 rounds, ADR 1.4 S, UN0012 certified fiberboard case
Weight (540 rounds)	Net: 6.48 kg (± 0.04 kg) Gross: 6.84 kg (± 0.04 kg) NEQ: 0.93 kg
Hazard class	1.4 S
UN Classification	CARTRIDGES, SMALL ARMS

Packaging options are available based on the buyer's request. Cartridges can be supplied in standard outer cartons or, for an additional cost, in metal M2A1 boxes. All shipments are palletized, with boxes and pallets marked according to the customer's specifications.

V = Corrected velocity
XCP = Corrected mean chamber pressure
XPP = Corrected mean Port Pressure
Mr = Mean radius

Outsourcing Components

ATS® Ammunition has its own top-to-bottom manufacturing of a finished Product, an output of In-house made Machines, and produces 100% In-house Materials, Components and Tooling). ATS AMMO .223 Remington components (bullet, case, primer) are perfectly compact, customizable and *available for individual purchase*.

PRIMER
No mercury
CuZn30

<small>Case Length: max 44.70 mm</small>
CASE 5.56 x 45 mm
Unprimed
CuZn30

<small>Grain Bullet Length: max 19.5 mm</small>
M193 FMJ BALL
3.56 g 55 grain
CuZn10 Lead Core

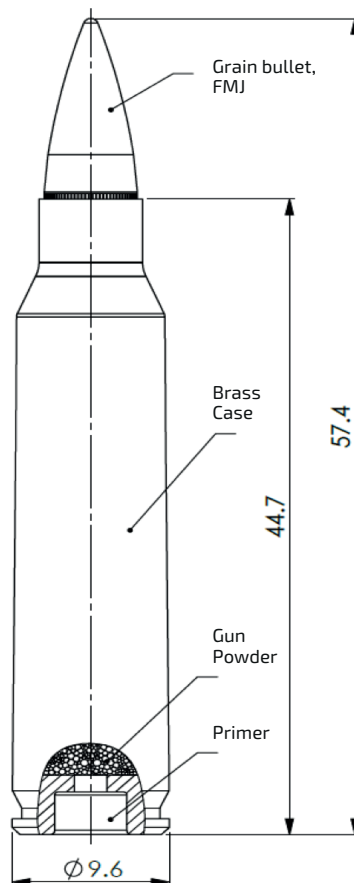

Image: Components Layout (.223 Remington)
Part number: 5561093; NSN 1305-54-000-0137