



12.7 X 108 MM

BALL - 48 G (740 GR)

12.7 x 108 mm FMJ

The cartridge 12.7 is available with few bullet types. It's available for customer customizable configuration according to individual requirement.

SPECIFICATIONS

Technical Specification

CARTRIDGE

Caliber	12.7 x 99 mm, NATO
Weight	max 112 g
Length	max 138.4 mm

BULLET GRAIN

Type	FMJ, Ball
Weight	42 g ± 0.4 g (649 grain)
Length	max 58.6 mm
Material	Jacket - CuZn10; Core - Lead
Extraction	≥ 900 N

CASE

Length	max 99.31 mm
Material	CuZn30

PRIMER

Type	Boxer, non-corrosive, non-toxic
Propellant	Smokeless Powder (Double Base)
Waterproof	Sealant applied

The 12.7x99, NATO, Ball, ammunition producing in ATS AMMO is in compliance with NATO STANAG 4383 requirements. It's comply the the requirements to the NATO manuals AC/225(LG/3-SG/1)D/8 and PFP(NAAG-LCG/1-SG/1)WP(2010)0002. The ammunition can be fired from all NATO nominated 12.7x99 mm weapons: M2 HB BROWNING 12.7mm Machine Gun.

ELECTRONIC PRESSURE AND VELOCITY (KIAG 6215)			
Ammunition Temperature	+21°C ± 2°C	+52°C & -54°C	
Velocity (at 24 m, m/s)	$V = 890 \pm 10 \text{ m/s}$	No requirement	
Standard Deviation	$\leq 12 \text{ m/s}$	No requirement	
Max Corrected Mean Case Mouth Pressure, MPa	$XCP + 3SD \leq 450 \text{ Mpa}$	No requirement $XCP + 3SD \leq 450 \text{ Mpa}$	
Min Corrected Mean Port Pressure, MPa	No requirement	No requirement	
Action Time (ms)	No requirement	Max Mean Action Time + 5SD for -54°C sample $\leq 4.5 \text{ ms}$	
Muzzle Energy (at 24 m, J)	No requirement	No requirement	
Precision (at 550 m)	$HSD \leq 300 \text{ mm}$ and $VSD \leq 300 \text{ mm}$		
Function and Casualty	Permissible percentage of defects was not exceeded		
Primer sensitivity critical high method (run down)	Test ball $225.1 \pm 0.57 \text{ g}$	H +5 SD ≤ 380	H - 2 SD ≥ 63
Min Corrected Mean Port Pressure, MPa	$XPP - 3SD \leq 103 \text{ Mpa}$	Max port pressure difference between +52°C/ -54°C and 21°C samples is $\pm 15 \text{ Mpa}$ $XPP - 3SD \geq 103 \text{ Mpa}$	
Terminal effects at distance 100 m, perforation rolled homogeneous armor plate, mild steel witness screen (500 m behind armor plate)	At least one shall completely perforate 22 mm (Brinell hardness 321–375), and at least one splinter shall perforate the witness screen 1.5mm Mild Steel (S235 JRG2 or HE280M)		
Trajectory match	Horizontal $550 \text{ m} \leq 550 \text{ mm}$ $900 \text{ m} \leq 900 \text{ mm}$	Vertical $550 \text{ m} \leq 385 \text{ mm}$ $900 \text{ m} \leq 630 \text{ mm}$	
Waterproof test	No more than 15% of the tested rounds have leaks		

Compatibility with: AC/225(LG/3-SG/1)D/8 and PFP(NAAG-LCG/1-SG/1)WP(2010)0002 and STANAG 4383

PACKING	
Makro	1 (one) metal box M2A1: 140 cartridges 1 (one) wooden case for transportation: 2 (two) metal boxes Totally: 280 cartridges in 1 (one) wooden box
Weight (100 rounds)	Net: 11.15 kg Gross: 12.00 kg NEQ: 1.4 kg
Hazard class	1.4 S
UN Classification	CARTRIDGES, SMALL ARMS

Packaging can be arranged based on the request of the buyer and cartridges supplied in either outer carton or metal M2A1 boxes, palletized. The boxes and pallets shall be marked according to the requirements of the customer.

V = Corrected velocity
XCP = Corrected mean chamber pressure
XPP = Corrected mean Port pressure
HSD = Horizontal standard deviation
VSD = Vertical standard deviation
Mr = Mean radius

Test Equipment



The equipment that is used for testing the ballistic characteristics of the ammunition is from Prototypa and is as follows:

- Universal Ballistic Breech (Receiver) UZ-2002
- Support reducing inserter UZ-2002
- Exchangeable parts sets for cal. 12.7x99 mm - for action time measuring:
 - Breech block head insulated marked 3 INM
 - Firing pin insulated marked 3 INA
 - Extractor marked 1
 - Firing pin spring
 - Extractor spring
 - Extractor cap
 - Rivet 3x8
 - Firing pin end
- Pressure Test Barrel cal. 12.7x99 mm for Receiver M2; Length = 1143 mm, KISTLER 6215 pressure vent position, M2=103.2 mm
- Velocity/Accuracy Test Barrel cal. 12.7x99 mm for Receiver M2; Length = 1143 mm Head space gauge GO and NOGO cal. 12.7x99 mm.
- SAU-4QU Signal acquisition unit
 - 4 charge inputs for transducers/voltage inputs (programmable)
- Quartz High pressure Sensor KISTLER 6215A1
- LS06 Intelligent Light gates
 - Diode system, Base 1 m, software BMS - English
- BP-1 Bullet pull tester.
 - Range of calibers from 4,5 to 12 mm
 - Maximum load 5000 N

The equipment is controlled, maintain, and calibrated according to the specifications. We are always aiming for improving the testing facility with latest in line equipment's and assuring that the possibility of mistake is reduced to the minimum.

Outsourcing Components

ATS® Ammunition has its own top-to-bottom manufacturing of a finished Product, an output of In-house made Machines, and produces 100% In-house Materials, Components and Tooling). ATS AMMO 12.7 x 99 mm components (bullet, case, primer) are perfectly compact, customizable and *available for individual purchase*.

 <small>Case Length: 99 mm</small>	
CASE 12.7 x 99 mm	NATO M33
Unprimed	42.31 g 653 grain
CuZn30	CuZn10 Steel Core

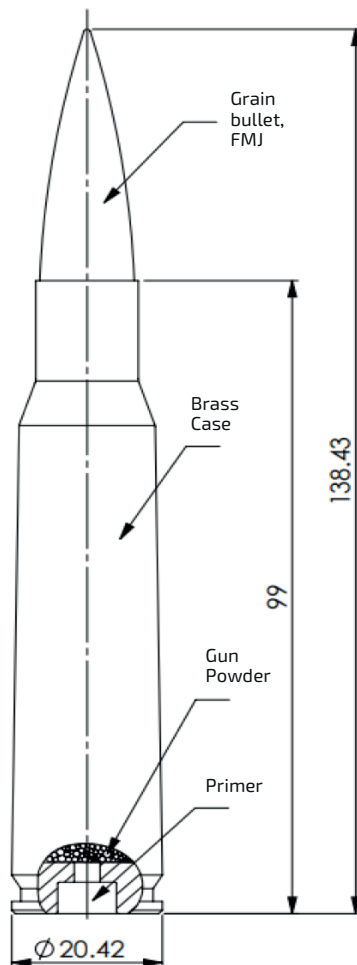

Image: Components Layout (12.7 x 99 mm)
Part number: 1271099